

# STOLTZEN<sup>®</sup>

## APOLLO

### 4K HDMI over IP Encoder & Decoder w/ KVM



**SA-6000E & SA-6000D**  
USER MANUAL

# Important Safety Information

1. Read, follow, and keep these instructions.
2. Heed all warnings.
3. Do not use this product near water. Keep away from wet places, such as: spas, pools, sinks, laundries, wet basements, etc.
4. When cleaning, unplug the unit and wipe with a dry cloth. Do not use damp cloths, cleaning fluids, or aerosols which may result in electric shock, fire, or unit damage.
5. Operate this product using only the included power supply and/or power cable. Use of an unapproved power implement may impair performance, damage the product, or cause fires.
6. Do not block any ventilation openings. Install in accordance with the manufacturer's instructions.
7. Do not install or place this product near any heat sources such as radiators, heat registers, stoves, or other apparatus (including amplifiers) that produce heat.
8. Protect the power cord from being walked on or pinched particularly at plugs, convenience receptacles, and the point where they exit from the product.
9. Only use attachments/accessories specified by Stoltzen to avoid fire, shock, or other hazards.
10. To reduce the risk of electric shock and/or damage to this product, never handle or touch this unit or power cord if your hands are wet or damp. Do not expose this product to rain or moisture.
11. Unplug this product during lightning storms or when unused for long periods of time.
12. Never open, remove unit panels, or make any adjustments not described in this manual. Attempting to do so could result in electric shock, damage to the unit, or other hazards.



The lightning flash with arrowhead symbol, within an equilateral triangle, is intended to alert the user to the presence of uninsulated dangerous voltage within the product's enclosure that may be of sufficient magnitude to constitute a risk of electric shock to persons.



The exclamation point within an equilateral triangle is intended to alert the user to the presence of important operating and maintenance (servicing) instructions in the literature accompanying the appliance.

## CAUTION

TO REDUCE THE RISK OF ELECTRIC SHOCK  
DO NOT OPEN ENCLOSURE OR EXPOSE  
TO RAIN OR MOISTURE.  
NO USER-SERVICEABLE PARTS  
INSIDE REFER SERVICING TO  
QUALIFIED SERVICE PERSONNEL.

# Contents

Important Safety Information.....	1
Introduction.....	3
Features .....	3
Package Contents .....	5
Panel Description.....	7
Encoder .....	7
Front Panel.....	7
Rear Panel .....	8
Decoder .....	9
Front Panel.....	9
Rear Panel .....	10
Specifications.....	12
Encoder .....	12
Decoder .....	14
Installation.....	15
Typical Application .....	16
Scenario 1 .....	16
Scenario 2 .....	17
Hardware Installation .....	18
Operating the Devices .....	19
Introduction to Different Operation Tools .....	19
Using DIP Switch to Perform Routing.....	20
Using PC Configurator to Perform Routing.....	20
Using PC Configurator to Perform Fast Switching.....	20
Configuring Mouse Roaming .....	21
Configuring before HDR10 Signal Input.....	25
Firmware Upgrade .....	26

# Introduction

SA-6000E encoders and SA-6000D decoders provide the flexible, powerful, and scalable solution at resolutions up to 3840 x 2160@60Hz 4:2:0, 3840 x 2160@30Hz 4:4:4. They allow 4K UHD media to be switched and distributed over standard gigabit Ethernet networks, providing complete end-to-end streaming systems. Audio, video together with IR, and USB signals can be routed separately or as a whole throughout the matrix system. Encoders can be used with decoders to function video wall up to the dimensions of 16 x 16. Both of them have the capacity to handle and output up to 7.1 channel audio, allowing you to enjoy the finest sound.

HDCP 2.2 specifications are employed. A local area network is covered with a range up to 330ft (100m) over a single Cat 5e cable or above. Standard features like bi-directional serial, bi-directional IR, and independent analog audio input/output are included. The codecs allow USB extension to take place to control a keyboard and a mouse. They offer integration-friendly control features -- the front panel link DIP switch, Windows PC configurator (Apollo Configurator), Apollo Visual Composer Touch on iPad and IP control box (SA-C), providing simple, flexible control and management options. They are the perfect solution for any low latency and signal routing applications. Common applications include homes, classrooms, conference rooms and broadcasts.

## Features

- Distributes and switches 4K UHD AV signals via standard gigabit Ethernet networks, providing complete end-to-end streaming systems.
- Encoder supports HDMI input and output resolutions up to 3840 x 2160@60Hz 4:2:0.
- Decoder supports HDMI output resolutions up to 3840 x 2160@30Hz

4:4:4.

- Supports streaming resolutions up to 3840 x 2160@30Hz 4:4:4.
- Features video wall up to the dimensions of 16 x 16.
- Supports HDR10.
- Supports CEC one-touch-play and standby commands to power on/off the display, as well as CEC Frame.
- Supports multi-channel audio up to PCM 7.1, Dolby Atmos and DTS:X.
- Supports independent analog audio input and output at 2 channels, 24 bits@48 kHz/channel.
- HDCP 2.2 compliant.
- Flexible routing policies, allowing audio, video, USB, IR and RS232 signals to be routed separately or as a whole throughout the matrix system.
- Allows AV, USB, IR, RS232 and power signals to be delivered up to 330ft/100m over a single Cat 5e cable or above.
- Allows video output to follow input resolution or to convert the input resolution to 3840 x 2160@30Hz 4:4:4 and 1080p@60Hz.
- Supports HDMI input and output transmission distance up to 50ft/15m.
- 1 ~ 2 fps latency.
- Supports bi-directional serial communication, allowing control of remote RS232 devices between encoders/decoders and IP control box, or between encoders and decoders.
- Supports bi-directional IR pass-through, allowing control of remote source and display devices between encoders and decoders.
- Supports IR generation – send IR codes through API.
- Encoder offers a USB type B port to directly connect to a PC and complies with USB 2.0 standard.
- Decoder offers two USB type A ports to directly connect to a keyboard and a mouse and complies with USB 2.0 standard, providing +5 VDC at up to 500 mA to connected USB peripherals.

- Supports Mouse Roaming. (See [Configuring Mouse Roaming](#) section for more information)
- Supports point-to-point, point-to-multipoint, multipoint-to-point, multipoint-to-multipoint applications.
- Supports PoE to be remotely powered by compatible power source equipment such as a PoE-enabled Ethernet switch, eliminating the need for a nearby power outlet.
- Supports user-selectable output HDCP configuration via PC configurator.
- Fit in/stretch out video wall, and rotate video management -- Decoded video can fill a video wall, maintain aspect ratio in a video wall, or can be rotated 180° and 270° clockwise, presenting imagery that meets customer expectations.
- Supports Auto IP, zero-configuration networking (zeroconf), a set of special technologies that automatically assign dynamic IP addresses to the devices on startup and a server-less method of choosing an IP address.
- Works with multiple operation tools, the front panel link DIP switch, Windows PC configurator, Apollo Visual Composer Touchon iPad and IP control box for device control and management.
- Supports communications protocols used on the Ethernet such as TCP/IP, ARP, DHCP, ICMP (ping), IGMP, UDP.

## Package Contents

### Encoder

- 1 x SA-6000E Unit
- 1 x Phoenix Male Connector (3.5mm, 3 Pins)
- 1 x IR Emitter (3.9ft/1.2m)
- 1 x Broadband IR Receiver (3.9 ft/1.2 m, 30 kHz ~ 50 kHz)
- 2 x Mounting Brackets

**Decoder**

- 1 x SA-6000D Unit
- 1 x Phoenix Male Connector (3.5mm, 3 Pins)
- 1 x IR Emitter (3.9ft/1.2m)
- 1 x Broadband IR Receiver (3.9 ft/1.2 m, 30 kHz ~ 50 kHz)
- 2 x Mounting Brackets

# Panel Description

## Encoder

### Front Panel



No	Name	Description
1	Power LED	<ul style="list-style-type: none"><li>On: SA-6000E is powered on.</li><li>Off: SA-6000E is powered off.</li></ul>
2	Status LED	<ul style="list-style-type: none"><li>Solid on: SA-6000E is connected to both an active video source and SA-6000D.</li><li>Blinking: SA-6000E is disconnected from an active video source. / SA-6000E is disconnected from SA-6000D.</li><li>Off: SA-6000E is powered off or in the boot process. / Network is down.</li></ul>
3	Mode	Use this switch to toggle between normal and debug modes. <ul style="list-style-type: none"><li>Normal (Default): In this mode, you can connect the rear panel RS232 port to a RS232 device such as a computer for bi-directional serial communication with a RS232 device on the IP control box side.</li><li>Debug: In this mode, you can connect the rear panel RS232 port to a RS232 device such as a computer for debugging SA-6000E.</li></ul>
4	DIP	This DIP switch consists of four manual switches, which are used to route audio, video together with IR, and USB signals between SA-6000E and SA-6000D based on their positions. By default, each individual switch is in the up position. For more information, see "Using DIP Switch to Perform Routing". <b>Note:</b> For the DIP switches in both encoder and decoder, changes to them take effect immediately without rebooting the system.



# Rear Panel

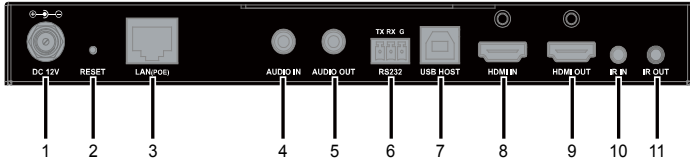

No.	Name	Description								
1	DC 12V	Connect this port to a 12 V 1 A power adapter.								
2	Reset	Use this button to reset device. When SA-6000E is powered on, use a pointed stylus to hold down this button for five or more seconds, and then release it, it will reboot and restore to its factory defaults.								
3	LAN (PoE)	10/100/1000 Base-T port, connect this port to a gigabit Ethernet switch for IP stream output, device control and management. <table border="1" style="width: 100%; border-collapse: collapse;"> <thead> <tr> <th colspan="2">Default Protocol</th> </tr> </thead> <tbody> <tr> <td>Default IP Mode</td> <td>Auto IP</td> </tr> <tr> <td>IP Address</td> <td>169.254.x.x</td> </tr> <tr> <td>Subnet mask</td> <td>255.255.0.0</td> </tr> </tbody> </table>	Default Protocol		Default IP Mode	Auto IP	IP Address	169.254.x.x	Subnet mask	255.255.0.0
Default Protocol										
Default IP Mode	Auto IP									
IP Address	169.254.x.x									
Subnet mask	255.255.0.0									
4	Audio In	Connect this 3.5 mm stereo tip-ring-sleeve port to an audio source such as a computer for unbalanced stereo audio signal input.  <b>Note:</b> When this audio port is connected to an audio source, both encoder and decoder will output the audio signal from the audio source instead of that from the HDMI video source. If this audio port is connected via an audio cable but no audio signals are input, you can get picture but no sound. The situations above do not apply to the HDMI loop-through port in encoder, which can still output the AV signals from the video source.								
5	Audio Out	Connect this 3.5 mm stereo tip-ring-sleeve port to an audio receiver such as a speaker or amplifier for unbalanced, stereo audio signal output.								
6	RS232	Use this port to perform bi-directional serial communication and device debug functions. <ul style="list-style-type: none"> <li>When the front panel "MODE" switch is moved to the "NORMAL" position, connect this port to a RS232 device such as a computer to bi-directionally communicate with a RS232 device at the IP control box side.</li> <li>When the front panel "MODE" switch is toggled to</li> </ul>								

No.	Name	Description
		the "DEBUG" position, connect this port to a RS232 device such as a computer for debugging SA-6000E.
7	USB Host	Connect a type A male to type B male USB cable between this port and the USB port of a desktop or laptop. SA-6000E is USB 2.0 compliant.
8	HDMI IN	Connect this port to an HDMI source device.
9	HDMI OUT	Connect this port to a local HDMI display device.
10	IR IN	Connect this port to an IR receiver for IR communication with an IR emitter at the SA-6000D side on the network.
11	IR OUT	Connect this port to an IR emitter for IR communication with an IR receiver at the SA-6000D side on the network.

## Decoder

### Front Panel

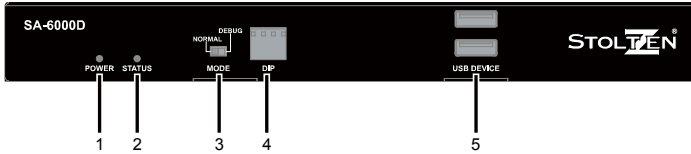

No.	Name	Description
1	Power LED	<ul style="list-style-type: none"> <li>On: SA-6000D is powered on.</li> <li>Off: SA-6000D is powered off.</li> </ul>
2	Status LED	<ul style="list-style-type: none"> <li>On: SA-6000D is connected to SA-6000E and the video is displayed.</li> <li>Blinking: SA-6000D is disconnected from SA-6000E.</li> <li>Off: SA-6000D is powered off or in the boot process. / Network is down.</li> </ul>
3	Mode	<p>Use this switch to toggle between normal and debug modes.</p> <ul style="list-style-type: none"> <li>Normal (Default): In this mode, you can connect the rear panel RS232 port to a RS232 device such as a computer for bi-directional serial communication with a RS232 device on the IP control box side.</li> <li>Debug: In this mode, you can connect the rear panel RS232 port to a RS232 device such as a computer for debugging SA-6000D.</li> </ul>

No.	Name	Description
4	DIP	<p>This DIP switch consists of four manual switches, which are used to route audio, video together with IR, and USB signals between SA-6000E and SA-6000D based on their positions. By default, each individual switch is in the up position. For more information, see "Using DIP Switch to Perform Routing".</p> <p><b>Note:</b></p> <p>For the DIP switches in both encoder and decoder, changes to them take effect immediately without rebooting the system.</p>
5	USB Device	<p>Connect the two USB type A ports to a USB keyboard and mouse. The connections are USB 2.0 compatible, providing +5 VDC at up to 500 mA to connected USB peripherals.</p>

## Rear Panel

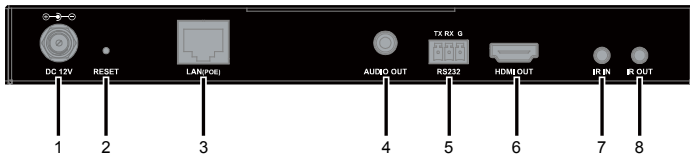

No.	Name	Description
1	DC 12V	<p>Connect this port to a 12 V 1 A power adapter.</p>
2	Reset	<p>Use this button to reset device or quickly remove link relationship between decoder and encoder.</p> <ul style="list-style-type: none"> <li>Device reset: When SA-6000D is powered on, use a pointed stylus to hold down the Reset button for five or more seconds, and then release it, it will reboot and restore to its factory defaults. This function will disconnect decoder from encoder.</li> <li>Remove decoder and encoder link relationship quickly: When encoder is routed to decoder using PC configurator, Apollo Visual Composer Touch or IP control box, hold down the Reset button for less than five seconds, and then release it, it reverts to the link relationship between encoder and decoder set via the link DIP switch. This function applies to decoder only.</li> </ul>
3	LAN (POE)	<p>10/100/1000 Base-T port, connect this port to a gigabit Ethernet switch for IP stream input, device control and</p>

No.	Name	Description								
		<p>management.</p> <table border="1"> <thead> <tr> <th colspan="2">Default Protocol</th> </tr> </thead> <tbody> <tr> <td>Default IP Mode</td> <td>Auto IP</td> </tr> <tr> <td>IP Address</td> <td>169.254.x.x</td> </tr> <tr> <td>Subnet mask</td> <td>255.255.0.0</td> </tr> </tbody> </table>	Default Protocol		Default IP Mode	Auto IP	IP Address	169.254.x.x	Subnet mask	255.255.0.0
Default Protocol										
Default IP Mode	Auto IP									
IP Address	169.254.x.x									
Subnet mask	255.255.0.0									
4	Audio Out	Connect this 3.5 mm stereo tip-ring-sleeve port to an audio receiver such as a speaker or amplifier for unbalanced, stereo audio signal output.								
5	RS232	<p>Use this port to perform bi-directional serial communication and device debug functions.</p> <ul style="list-style-type: none"> <li>When the front panel "MODE" switch is moved to the "NORMAL" position, connect this port to a RS232 device such as a computer to bi-directionally communicate with a RS232 device at the IP control box side.</li> <li>When the front panel "MODE" switch is toggled to the "DEBUG" position, connect this port to a RS232 device such as a computer for debugging SA-6000D.</li> </ul>								
6	HDMI OUT	Connect this port to an HDMI display device.								
7	IR IN	Connect this 3.5 mm tip-ring-sleeve port to an IR receiver for IR communication with an IR emitter in the SA-6000E side on the network.								
8	IR OUT	Connect this 3.5 mm tip-sleeve port to an IR emitter for IR communication with an IR receiver in the SA-6000E side on the network.								

# Specifications

## Encoder

Technical	
Input Video Port	1 x female HDMI type A (19 pins)
Input Video Type	HDMI, HDCP 2.2
Input Resolution	3840 x 2160p@24Hz 4:4:4, 3840 x 2160p@30Hz 4:4:4, 3840 x 2160p@50Hz 4:2:0, 3840 x 2160p@60Hz 4:2:0, 640 x 480p@60Hz, 720 x 480p@60Hz 1280 x 720p@60Hz, 1920 x 1080i@60Hz, 1920 x 1080p@60Hz, 720 x 576p@50Hz 1280 x 720p@50Hz, 1920 x 1080i@50Hz 1920 x 1080p@50Hz, 1920 x 1080p@24Hz 1920 x 1080p@25Hz, 640 x 480@60Hz, 800 x 600@60Hz  1024 x 768@60Hz, 1280 x 720@60Hz 1280 x 768@60Hz, 1280 x 800@60Hz 1280 x 960@60Hz, 1280 x 1024@60Hz 1360 x 768@60Hz, 1366 x 768@60Hz 1400 x 1050@60Hz, 1440 x 900@60Hz 1600 x 900@60Hz, 1600 x 1200@60Hz 1680 x 1050@60Hz, 1920 x 1080@60Hz 1920 x 1200@60Hz
Input Video Signal	0.5~1.2 V p-p
Input DDC Signal	5 V p-p (TTL)
Average Encoding Data Rate	<ul style="list-style-type: none"><li>• 3840 x 2160@30Hz: about 250 Mbps</li><li>• 1080p@60Hz: about 150 Mbps</li></ul>
Output Video Port	<ul style="list-style-type: none"><li>• HDMI loop-through (local output): 1 x female HDMI type A (19 pins)</li><li>• Ethernet output: 1 x female RJ-45</li></ul>
Output Video Type	<ul style="list-style-type: none"><li>• HDMI loop-through (local output): HDMI, HDCP 2.2</li><li>• Ethernet output: IP stream</li></ul>
Output Resolution	<ul style="list-style-type: none"><li>• HDMI loop-through (local output): Up to 3840 x 2160@60Hz 4:2:0</li><li>• Ethernet output: Up to 3840 x 2160@30Hz 4:4:4</li></ul>
Video Impedence	100 Ω
End-to-End Time Latency	1 ~ 2 fps

Technical	
Maximum Pixel Clock	297 MHz
Max Video Data Rate	8.91 Gbps (2.97 Gbps per color)
Input Audio Port	<ul style="list-style-type: none"> <li>HDMI: 1 x female HDMI type A</li> <li>Audio In: 1 x 3.5 mm stereo jack</li> </ul>
Input Audio Format	<ul style="list-style-type: none"> <li>HDMI: LPCM 2.0/2.1/5.1/ 7.1; Dolby 5.1/7.1/Atmos; DTS 5.1/7.1/DTS:X</li> <li>Audio In: stereo</li> </ul>
Output Audio Port	<ul style="list-style-type: none"> <li>HDMI (local output): 1 x female HDMI type A (19 pins)</li> <li>Ethernet output: 1 x female RJ-45</li> <li>Audio Out: 1 x 3.5 mm stereo jack</li> </ul>
Output Audio Format	<ul style="list-style-type: none"> <li>HDMI: LPCM 2.0/2.1/5.1/ 7.1; Dolby 5.1/7.1/Atmos; DTS 5.1/7.1/DTS:X</li> <li>Ethernet: Dolby 5.1/Dolby True HD/Dolby Digital Plus, DTS 5.1/DTS HD/DTS True HD, LPCM 2.0/2.1/5.1/ 7.1</li> <li>Audio Out: Stereo</li> </ul>
Control Method	Front panel link DIP switch, Windows PC configurator (Apollo Configurator), IP control box, Apollo Visual Composer Touch on iPad

General	
Operating Temperature	0°C to 45°C (32°F to 113°F)
Storage Temperature	-20°C to 70°C (-4°F to 158°F)
Humidity	10% to 90%, non-condensing
ESD Protection	Human-body Model: ±8kV (Air-gap discharge)/ ±4kV (Contact discharge)
Power Supply	12 V 1 A DC
Power Consumption (Max.)	6W
Device Dimension (W x H x D)	8.7" x 1.0" x 5.1"/220 mm x 25 mm x 130.2 mm
Net Weight	0.74kg/1.63lbs

## Decoder

Technical	
Input Video Port	1 x female RJ-45
Input Video Type	IP stream
Input Resolution	Up to 3840 x 2160@30Hz 4:4:4
Output Video Port	1 x female HDMI type A (19 pins)
Output Video Type	HDMI, HDCP 2.2
Output Resolution	Up to 3840 x 2160@30Hz 4:4:4
Video Impedence	100 Ω
End-to-End Time Latency	1 ~ 2 fps
Input Audio Port	1 x female RJ-45
Input Audio Format	LPCM 2.0/2.1/5.1/ 7.1; Dolby 5.1/7.1/Atmos; DTS 5.1/7.1/DTS:X
Output Audio Port	<ul style="list-style-type: none"> <li>HDMI: 1 x female HDMI type A (19 pins)</li> <li>Audio Out: 1 x 3.5 mm Stereo jack</li> </ul>
Output Audio Format	<ul style="list-style-type: none"> <li>HDMI: LPCM 2.0/2.1/5.1/ 7.1; Dolby 5.1/7.1/Atmos; DTS 5.1/7.1/DTS:X</li> <li>Audio Out: Stereo</li> </ul>
Control Method	Front panel link DIP switch, Windows PC configurator (Apollo Configurator), IP control box, Apollo Visual Composer Touch on iPad

General	
Operating Temperature	0°C to 45°C (32°F to 113°F)
Storage Temperature	-20°C to 70°C (-4°F to 158°F)
Humidity	10% to 90%, non-condensing
ESD Protection	Human-body Model: ±8kV (Air-gap discharge)/ ±4kV (Contact discharge)
Power Supply	12 V 1 A DC
Power Consumption	4W (Max.)
Device Dimension (W x H x D)	8.7" x 1.0" x 5.1"/220 mm x 25 mm x 130.2 mm
Net Weight	0.74kg/1.63lbs

# Installation

**Note:** Before installation, please ensure the device is disconnected from the power source.

Steps to install the encoder in a suitable location:

1. Remove the four screws from the two side panels.

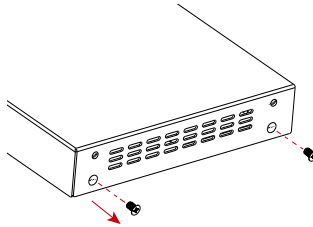

2. Position and install the mounting brackets on the two side panels using the mounting screws provided in package.

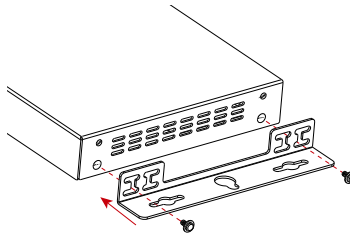

3. Attach the brackets to the surface you want to hold the unit against using the screws (provided by others).
4. Repeat the above steps for decoder.



# Typical Application

## Scenario 1

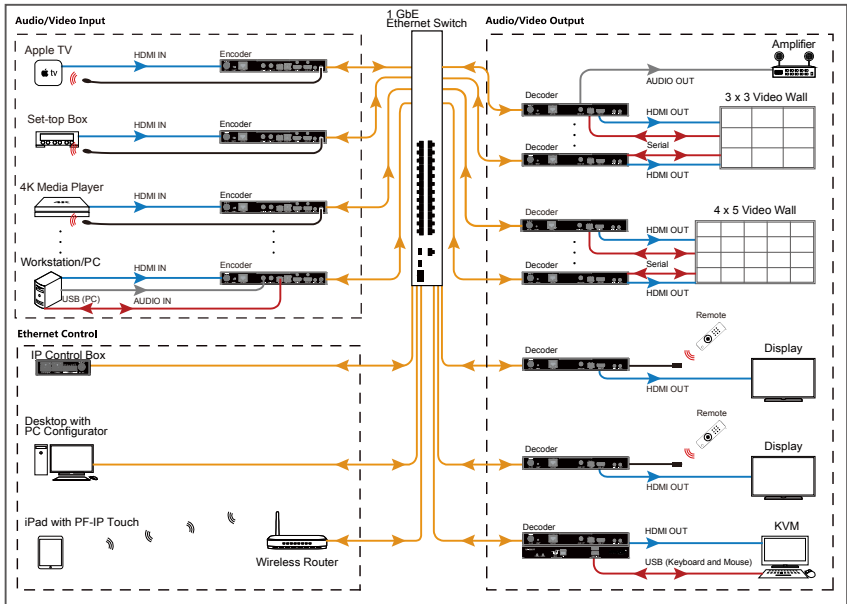

# Scenario 2

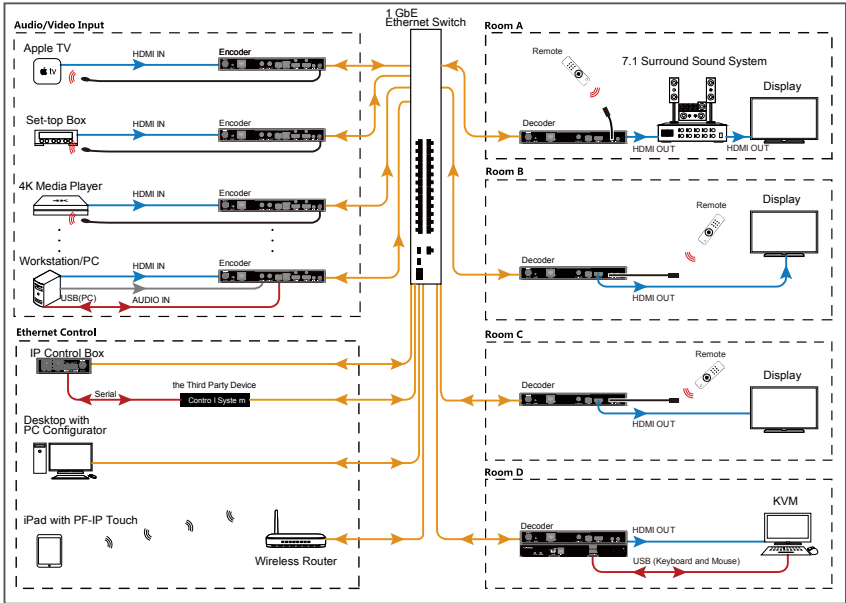

# Hardware Installation

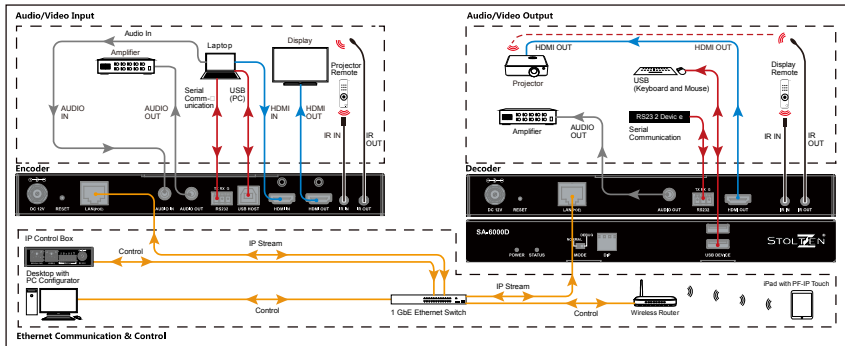

## Note:

- If the Ethernet switch doesn't support PoE, connect encoders and decoders to their power adapters.
- If the PoE switch is unable to provide enough power, connect encoders and decoders to their power adapters.

# Operating the Devices

## Introduction to Different Operation Tools

You can use the front panel link DIP switch, Apollo PC Configurator, Apollo Visual Composer Touch and IP control box to manage and control SA-6000E and SA-6000D codecs. This section briefly introduces how to route the video from source to the display using these tools. By default, audio, video together with IR, and USB signals are routed as a whole. For more information, see their guides.

The following tables describes how audio, video together with IR, and USB signals are routed using all the different tools.

Operation Tools	Description
Link DIP switch	Route audio, video together with IR, and USB signals as a whole.
PC configurator	
Apollo Visual Composer Touch	
IP Control Box	Both of the following routing policies are available. <ul style="list-style-type: none"><li>• Route audio, video together with IR, and USB signals as a whole.</li><li>• Route audio, video together with IR, and USB signals separately via IP controller's API commands.</li></ul>

**Note:**

- Operation tools PC configurator, Apollo Visual Composer Touch and IP control box take priority over the link DIP switch. Link relationship between encoder and decoder performed by the DIP switch can be changed using any other tools.
- When audio, video together with IR, and USB signals are routed via PC configurator, Apollo Visual Composer Touch and IP control box, press and hold the rear panel RESET button in decoder for less than five seconds to remove the current link relationship between encoder and decoder, reverting to the link relationship set by the link DIP switch.

- When audio, video together with IR, and USB signals are routed separately via IP control box's API commands, they can be routed as a whole with other operation tools.

## Using DIP Switch to Perform Routing

Before using the DIP switch, check that routing operations were not performed by other tools. Otherwise, the switch function is disabled. If so, press and hold the rear panel RESET button in decoder for less than five seconds to enable the DIP switch.

To route the video from source to display, toggle each individual switches of the front panel DIP switch in decoder to the same positions as these in encoder. If you want to link the decoder to a different encoder, change the decoder switch settings in the same way as how the encoder's switch is positioned. If you want to remove their link relationship, reset decoder to its factory defaults.

## Using PC Configurator to Perform Routing

In addition to matrix switching between encoders and decoders via PC configurator, it allows users to configure and manage them, including fast switching, video wall management, parameters setting, etc. For more information, see the user guide of PC configurator.

## Using PC Configurator to Perform Fast Switching

In addition to matrix switching between encoders and decoders via PC configurator, it allows users to configure them, including HDCP Hybrid and HDMI Timing Hybrid to function fast switching. For more information, see the user guide of PC configurator.

# Configuring Mouse Roaming

SA-6000E and SA-6000D codecs features Mouse Roaming. With configuration on PC Configurator (Apollo Configurator), you can move the mouse to the edge of the screen to control different computers in a system. They support one set of mouse and keyboard to control up to 16 host computers.

Take a 2 x 1 video wall for example to introduce how to configure Mouse Roaming as below:

1. Connect one computer to the HDMI IN and USB Host ports of each encoder; and one set of mouse and keyboard to the USB Hub ports of one decoder.

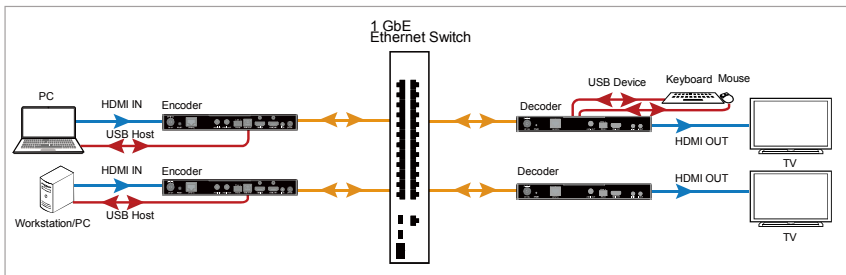

2. Launch the **Apollo Configurator.exe** on your computer to open its main page. (Ensure your PC, encoder and decoder are on the same subnet.) Click **Search** to search online devices.

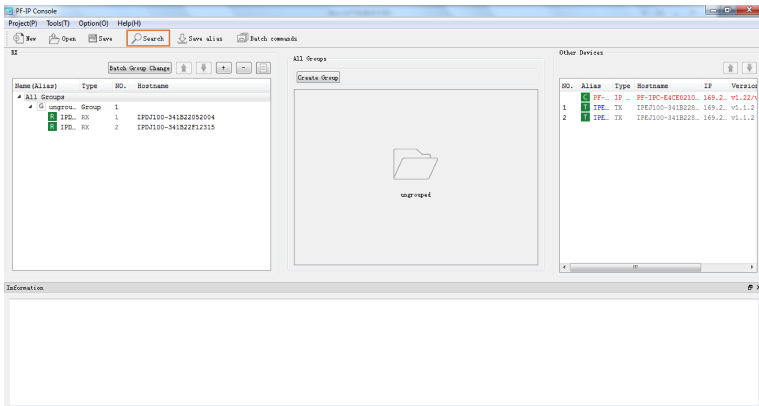

3. Create a video wall.

Click **ungrouped** in the RX list > **Create VW** > Name a video wall **VW1** and choose rows and columns > **OK**.

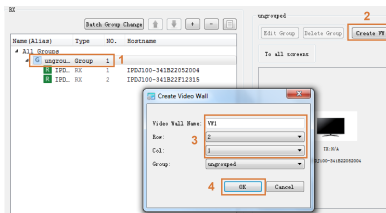

4. Create a layout for the video wall.

Click **VW1** in the RX list > **Create Layout/Scene** in the working area > name this layout **layout1** and choose **Mouse Roaming** > **OK**.

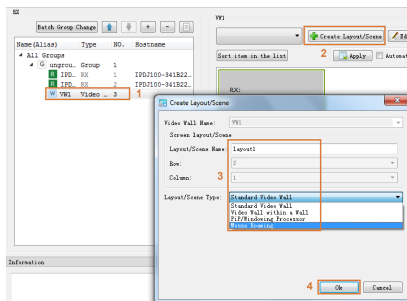

5. Configure decoder and encoder for layout1.

Drag decoders from the RX list and encoders from Other Devices area to display tiles in the working area.

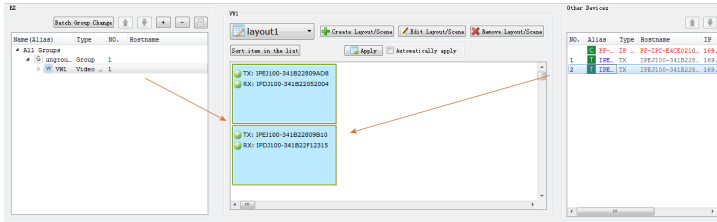

## 6. Configure Master and Slave.

Right click the RX to which the mouse and keyboard are connected and choose **Select Master** > right click the other one and choose **Select Slave** > Click **Apply** > **OK**.

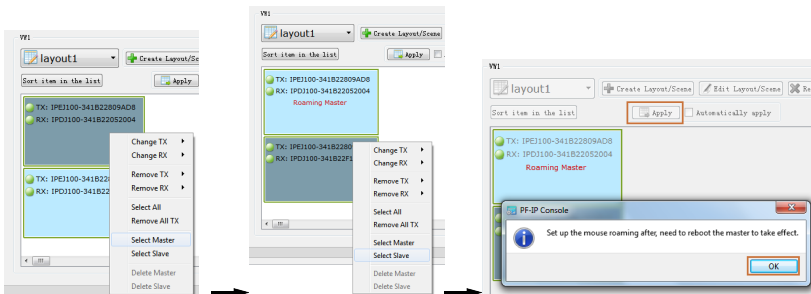

**Note:** To cancel Select Master/Select Slave setting, right click on the decoder and choose **Delete Master/Delete Slave**.

## 7. Reboot the decoder to make the Mouse Roaming configuration to take effect: click **Batch Commands** > **Others** > select decoder device > **Reboot** > **Apply**.

Please wait for a few seconds for the decoder device reboot.



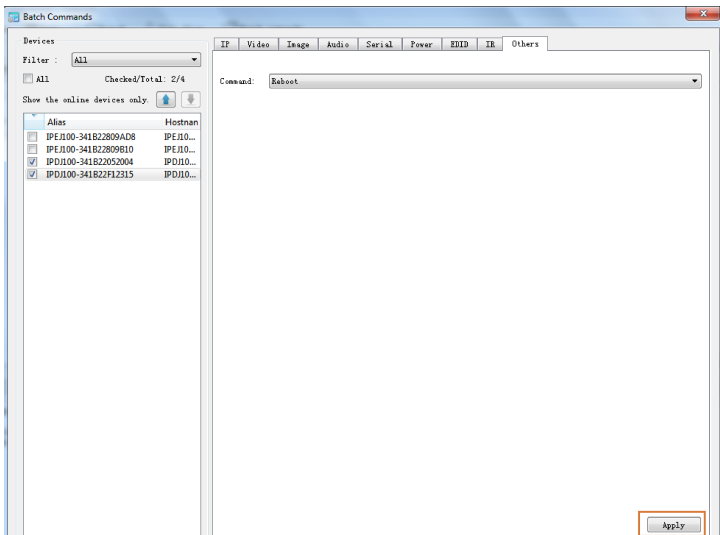
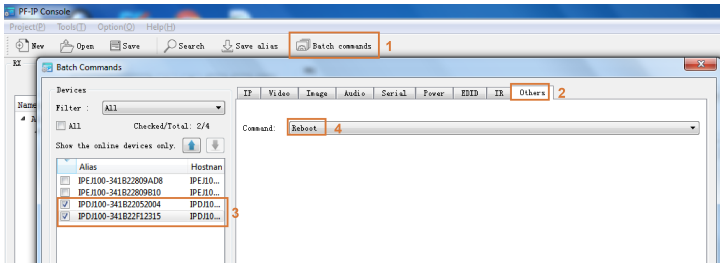

Now you can use the Master Roaming mouse to control both computers.

# Configuring before HDR10 Signal Input

SA-6000E and SA-6000D Support HDR10 only if the HDMI Timing Hybrid is set to “Pass-through” mode (default setting). Before you input HDR10 video, ensure the source and all displays support HDR10, and follow the steps below to configure the decoder through PF-PC Console.

1. Double click Apollo Configurator.exe. Click **Search** to search online devices.
2. Click **Batch Commands** to open Batch Commands window:  
Click **Video** Tab > Choose SA-6000D in the Devices list > Click **Pass-Through** from the drop down list in **HDMI Timing Hybrid** region > click **Apply**.

**Note:** The default setting for HDMI Timing Hybrid is **Pass-Through**.

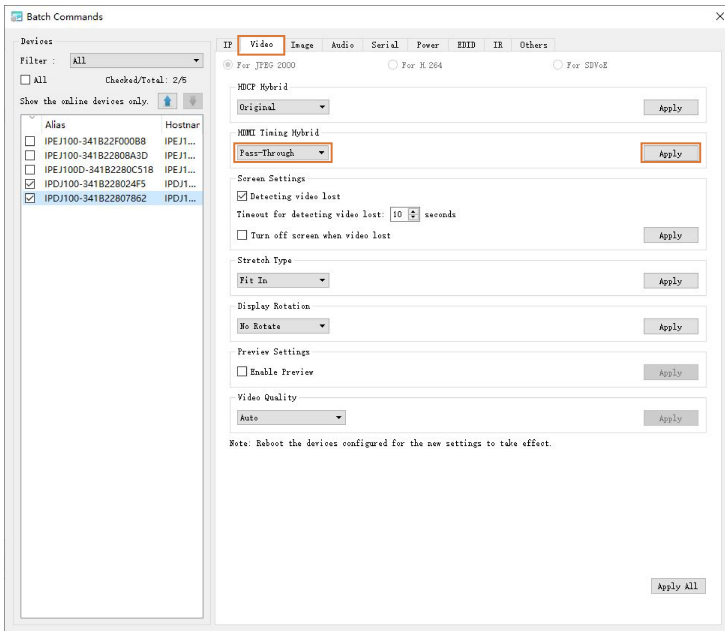

3. Reboot the devices configured for the new settings to take effect.  
Now you can play HDR10 video on your devices.

## Firmware Upgrade

You can use Apollo Maintenance Tool to update the encoders and decoders to their latest versions to obtain new features. For more information, see the user guide of Apollo Maintenance Tool.



Tel: +47 22 90 37 00 | <http://www.stoltzen.eu>

Sales: [sales@stoltzen.eu](mailto:sales@stoltzen.eu) | Technical: [support@stoltzen.eu](mailto:support@stoltzen.eu)

Address: Dronning Mauds Gate 15, 0250 OSLO, Norway